



# HANSON RIVET

& SUPPLY CO.  
13241 Weidner Street  
Pacoima, CA 91331

Phone: 818-485-0500

FAX: 818-485-0540

Outside CA: 1-800-RRRIVET

www.hansonrivet.com



## THREADED CLINCH NUTS





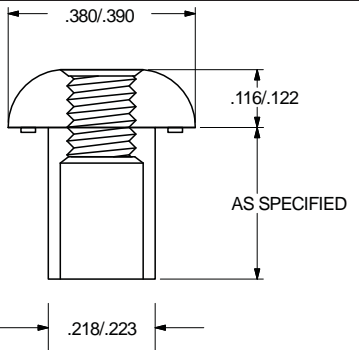

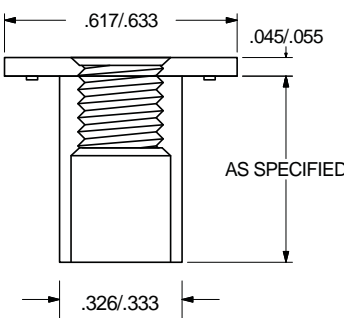

8-32 TAP STOCK SIZES	
PART NUMBER	LENGTH
RA-46331	3/16
RA-46332	1/4
RA-46333	5/16
RA-46334	3/8

1/4-20 TAP STOCK SIZES	
PART NUMBER	LENGTH
RA-46325	5/16
RA-46328	3/8
RA-46329	1/2
RA-46330	5/8

**Hanson Clinch Nuts** are internally threaded Tubular Rivets. The two styles above are some of our popular sizes we keep in stock in steel in the lengths noted. We can supply many different sizes, threads, head styles, materials, and finishes. Just let us know your requirements or use our Design-A-Rivet format on page C10.

**Uses of Clinch Nuts** are endless. They can be used to fasten two or more parts together like a standard Tubular Rivet while allowing additional parts to be attached with a screw. Some of the uses include: Abrasive Wheels, Stand -Offs, PC Boards, Electrical Contacts, Panel Mounting, and Electronic Enclosures. Installation is easy! Any of our riveters that will set a Tubular Rivets are ideal, including, Automatic Feed Machines, as seen on page C88 and C89 for high production. There is no faster way to put threads in thin sheets such as: Fibre Board, Metal, Plastic, Wood, Leather, Paper, Fiberglass, and Ceramic.

## BINDER POSTS & SCREWS

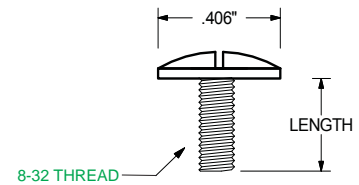
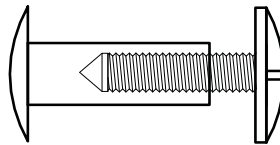
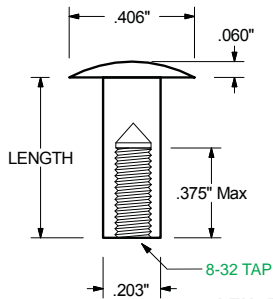

		FEMALE BINDER POSTS			
		CLOSED TRUSS HEAD	CLOSED FLAT HEAD	TAPPED THRU TRUSS HEAD	TAPPED THRU FLAT HEAD
<b>BRASS</b>	LENGTH UNDER HEAD			BPBT-0804T	
	1/4				
	3/8	BPBT-0806			
	1/2	BPBT-0808			
	3/4	BPBT-0812			
	1	BPBT-0816			

MALE BINDER SCREWS	
LENGTH UNDER HEAD	BRASS
5/16	BSBT-05

		ALUMINUM			
		CLOSED TRUSS HEAD	CLOSED FLAT HEAD	TAPPED THRU TRUSS HEAD	TAPPED THRU FLAT HEAD
<b>ALUMINUM</b>	3/16				BPAF-0803T
	1/4				BPAF-0804T
	3/8		BPAF-0804	BPAT-0804T	
	1/2	BPAT-0808	BPAF-0808	BPAT-0806T	
	5/8	BPAT-0810	BPAF-0810		BPAF-0808T
	3/4	BPAT-0812	BPAF-0812		
	7/8	BPAT-0814	BPAF-0814		
	1	BPAT-0816	BPAF-0816		
	1-1/4	BPAT-0820	BPAF-0820		
	1-1/2	BPAT-0824	BPAF-0824		
	1-3/4	BPAT-0828	BPAF-0828		
	2	BPAT-0832	BPAF-0832		
	2-1/4	BPAT-0836	BPAF-0836		
	2-1/2	BPAT-0840	BPAF-0840		
	2-3/4	BPAT-0844	BPAF-0844		
	3	BPAT-0848	BPAF-0848		
	3-1/4	BPAT-0852			
	3-1/2	BPAT-0856			
	4	BPAT-0864			
	4-1/2	BPAT-0872			
5	BPAT-0880				

LENGTH UNDER HEAD	ALUMINUM
3/16	BSAT-03
1/4	BSAT-04
3/8	BSAT-06

