



HANSON RIVET

& SUPPLY CO.
13241 Weidner Street
Pacoima, CA 91331

See pages C43-C46 for
installation tools

Phone: 818-485-0500
FAX: 818-485-0540

Outside CA: 1-800-RRRIVET
www.hansonrivet.com



SELF-PLUGGING BLIND RIVETS



Self-Plugging rivets offer a liquid and water resistant joint. Also greater strength, vibration resistance, and 100% mandrel retention!

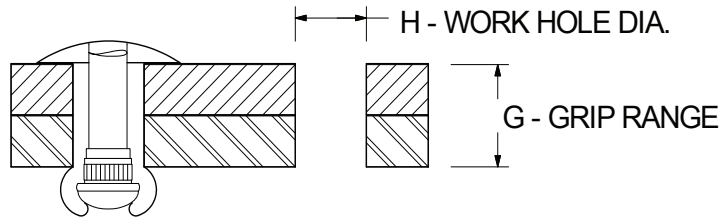
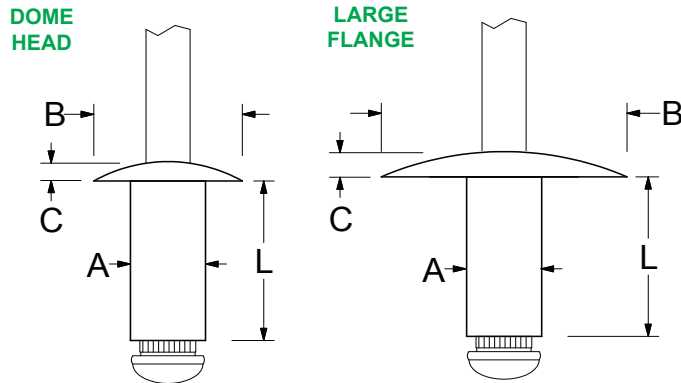

POP® SELF-PLUGGING RIVETS

RIVET MATERIAL MANDREL MATERIAL	HEAD STYLE	PART NUMBER	BODY DIAMETER "A"	WORK HOLE DIAMETER "H"	GRIP RANGE (SEE NOTE) "G"	BODY LENGTH (NOM.) "L"	HEAD DIAMETER (NOM.) "B"	HEAD HEIGHT (MAX.) "C"	TYPICAL ULTIMATE STRENGTHS IN LBS. (SEE NOTE)	
									SHEAR	TENSILE
	DOME HEAD	SD42SP-093 SD43SP-165 SD44SP-185 SD46SP-312	.121/.127 1/8	.129/.133	.063-.125 .150-.195 .185-.240 .312-.360	.250 .329 .391 .507	.250	.041	450	350
		SD55SP-218 SD56SP-241	.152/.158 5/32	.160/.164	.205-.260 .241-.368	.437 .562	.312	.050	525	500
		SD62SP-093 SD63SP-130 ESD64SP-187 SD64SP-220 SD68SP-437	.184/.190 3/16	.192/.196	.062-.125 .065-.187 .126-.250 .181-.272 .376-.500	.315 .378 .425 .440 .700	.375	.058	900	700
		SD82SP-093	.249/.255 1/4	.257/.261	.062-.125	.365	.500	.078	1750	1400
	LARGE FLANGE	SD52SP-093 SD54SP-129 SD56SP-129	.152/.158 5/32	.160/.164	.063-.125 .129-.256 .126-.343	.300 .417 .525	.468	.073	525	500
		SD68SP-225	.184/.190 3/16	.192/.196	.407-.467	.700	.625	.073	900	700
		SD64SP-187	.184/.190 3/16	.192/.196	.187-.235	.442	.625	.073	900	700
		SD64SP-187 SD65SP-225 SD66SP-210 SD66SP-225	.184/.190 3/16	.192/.196	.157-.217 .210-.327 .188-.384 .210-.375	.450 .575 .566 .566	.650	.091	900	700

NOTE: Part Number suffix is the work thickness that the mandrel will break flush with the head. (For example part number SD42SP-093 - .093 is the optimum work thickness)