



HANSON RIVET

& SUPPLY CO.
13241 Weidner Street
Pacoima, CA 91331

See pages C43-C46 for installation tools

Phone: 818-485-0500

FAX: 818-485-0540

Outside CA: 1-800-RRRIVET

www.hansonrivet.com



BLIND RIVETS



HOW THEY WORK!

A Blind Rivet consists of two parts: the rivet body and, within it, the setting mandrel.

1. The Blind Rivet body is inserted in a hole in the materials to be joined.
2. The Blind Rivet tool is placed over the mandrel. The tool is actuated and the jaws of the tool grip the mandrel.
3. The jaws retract, extracting the mandrel which pulls the mandrel head into the rivet body setting the rivet. At a predetermined tensile load, the mandrel breaks from its head and is discarded.

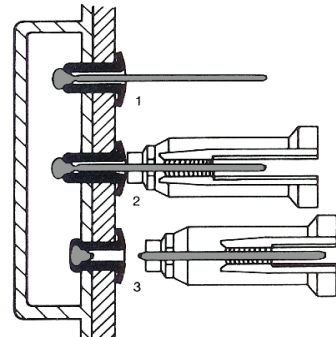

This forms a strong, tight, reliable joint. Because this is all done from one side these are called **BLIND** rivets.

DESIGN GUIDELINES

Channel Material

(A) If the nose housing of the tool is too large in diameter to reach the bottom of a channel, use a long nosepiece on the tool. A rivet with an extra long mandrel may be required.

(B) Install the rivet from the opposite side.

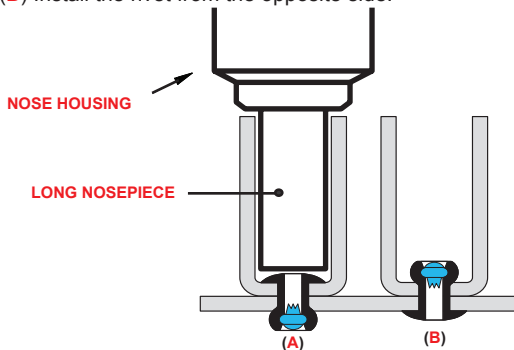

Gap Fastening

(A) Avoid riveting unsupported internal sections which may result in collapsing, dimpling or buckling the material.

(B) Select supported sections for best success.

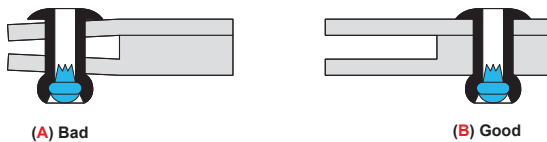

Pivot Fastening

When the fastened part must rotate on the rivet, a "pivot style" nosepiece on the rivet tool may be necessary to provide a small gap under the rivet head.

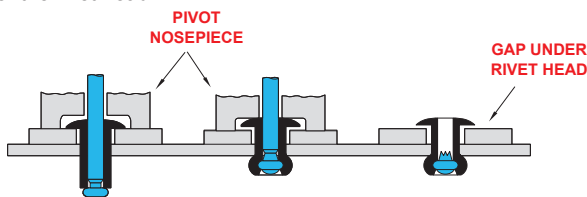

Fastening in a Blind Hole

Blind rivets may be set in a blind hole or milled slot. The success of this depends on the material of the parts to be riveted and the material of the rivet. Testing will be required.

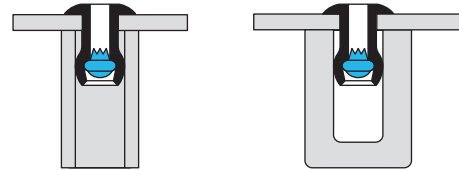

Riveting Plastic Material

Select: (A) "Soft Set" aluminum rivets see page C20, (B) Large Flange style rivets or (C) "Tri-Grip" rivets.

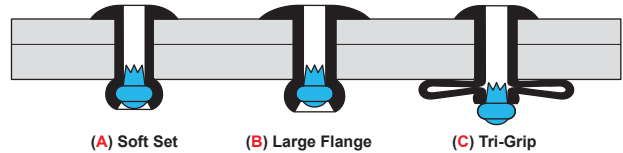

Hard to Soft Materials

The following illustration is a guide for using standard blind rivets to fasten hard materials to soft materials. Other options are to use Groove Rivets or T-Lok Rivets see page C32.

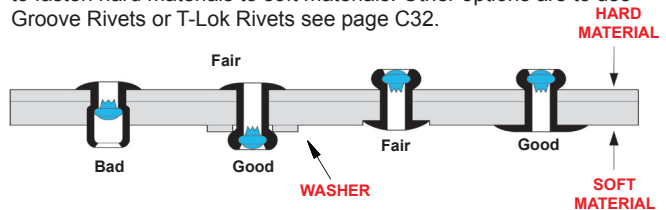

Edge Distance

We recommend 2 times the rivet body diameter (D) or more from the center of the rivet to the edge of the work piece to avoid material fracture.

